

(F)17-C and (F)18-C Concealed Top Latch Preparation

Panic and Exit Devices, (Fire Rated Device - No Metal Channel - Top Latch Reinforcing Plates Construction - 20 Minute), Wood Door, LHR Shown, RHR Opposite

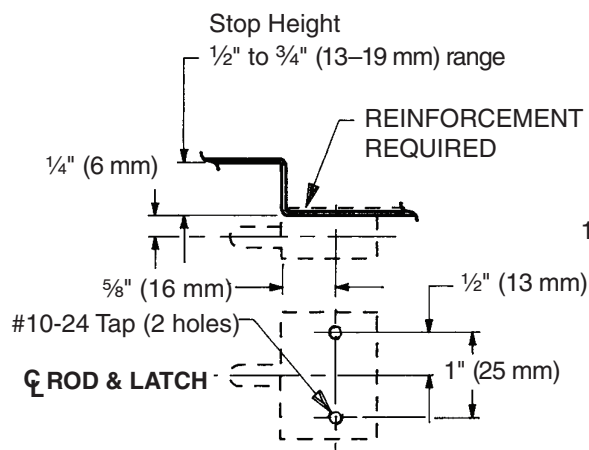

RELEASE PLUNGER DETAIL

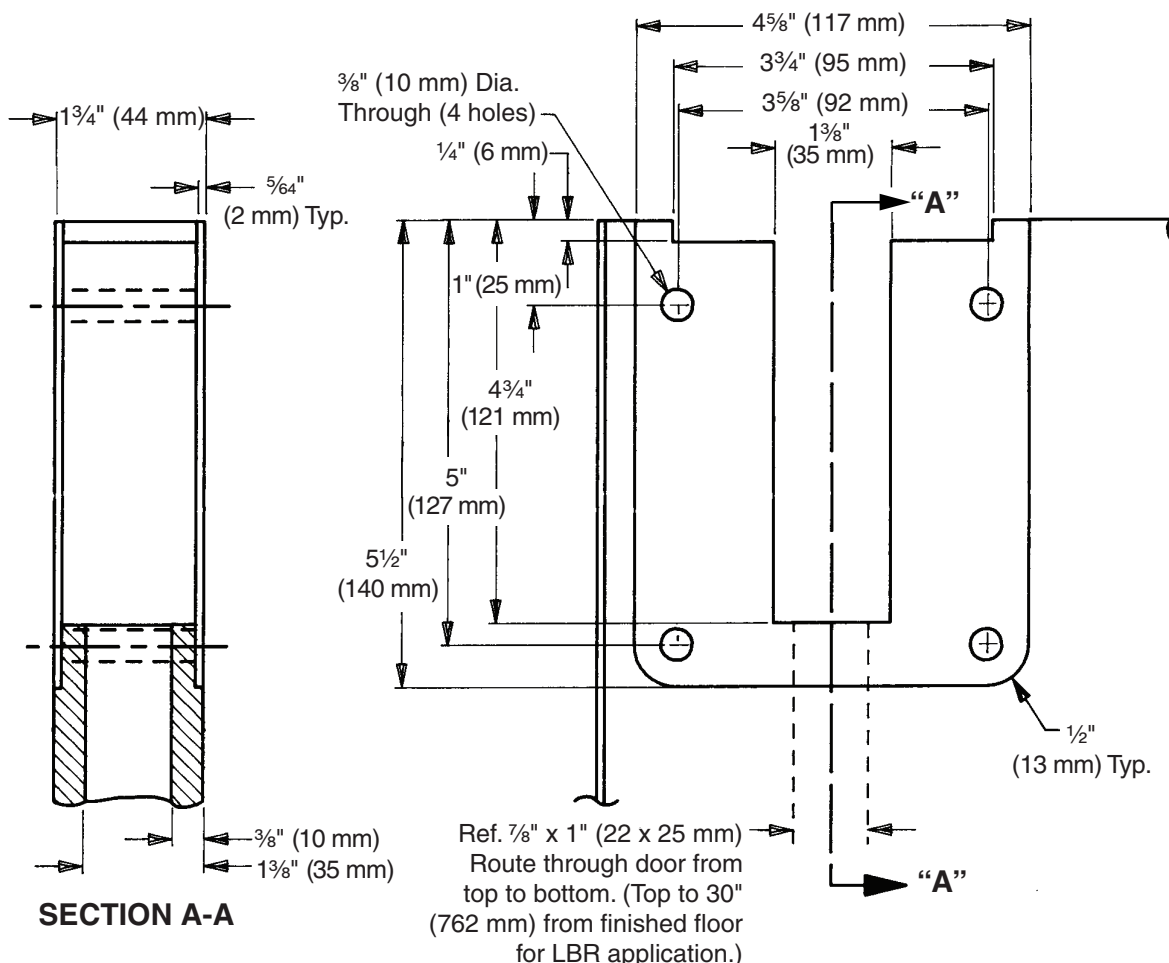
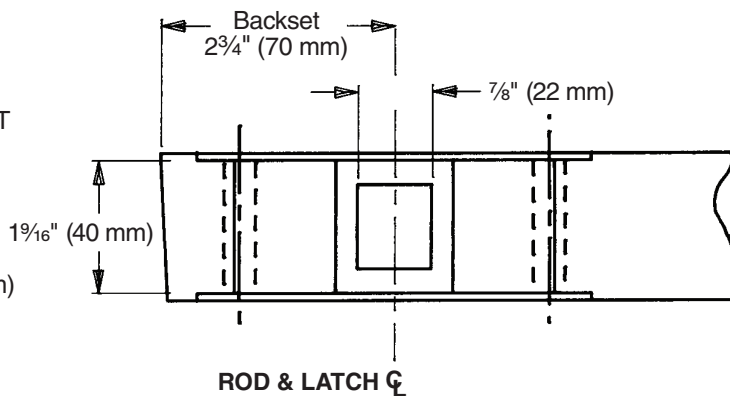

SECTION A-A

- For outside trim, see trim template for door preparation.
- For bottom bolt preparation, refer to Template W-1156.
- For (F)17 centerslide preparation, refer to Template W-1153.
- For Less Bottom Rod (LBR) application omit bottom bolt preparation. On fire rated applications, refer to Template W-5494 for auxiliary fire latch preparation.

TEMPLATE

W-1155-a