

F-17-C Concealed Vertical Device

Concealed Vertical Rod Fire Exit Devices, Metal Door, LHR Shown, RHR Opposite

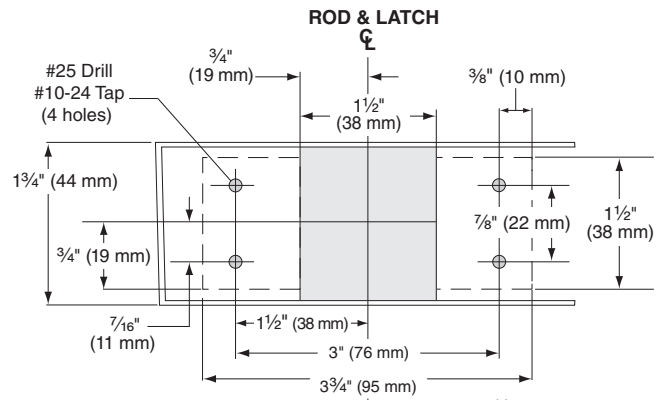

- For exit only devices, drill and tap for 1/4" - 20 machine screw (2 holes).
- For devices with trim, refer to trim template for door preparation.

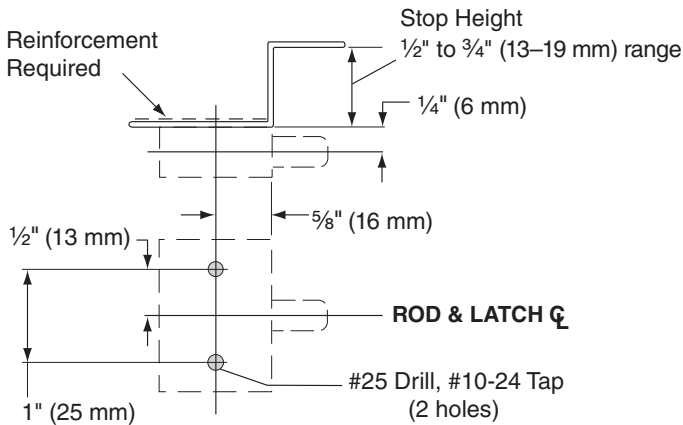
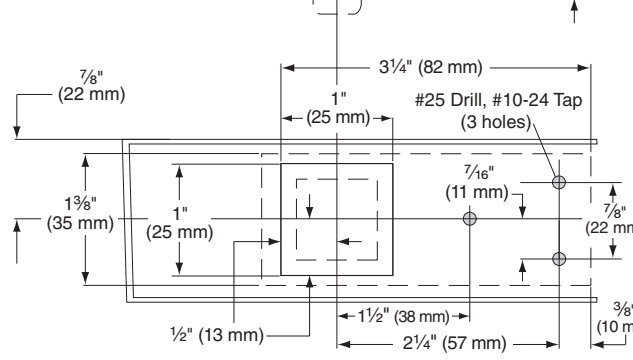
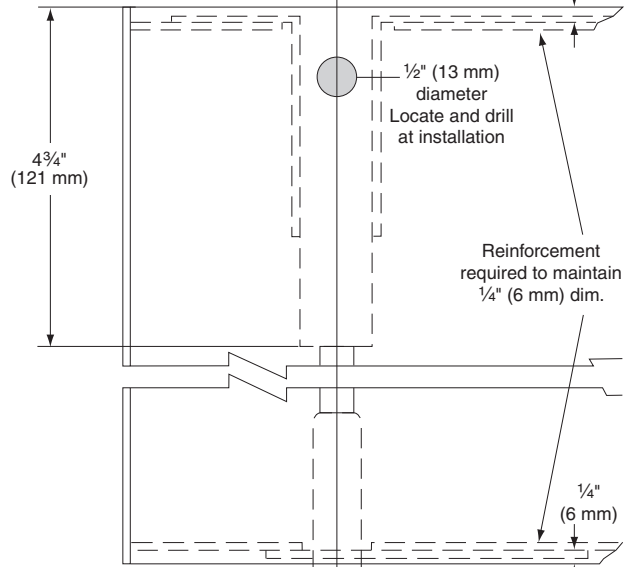
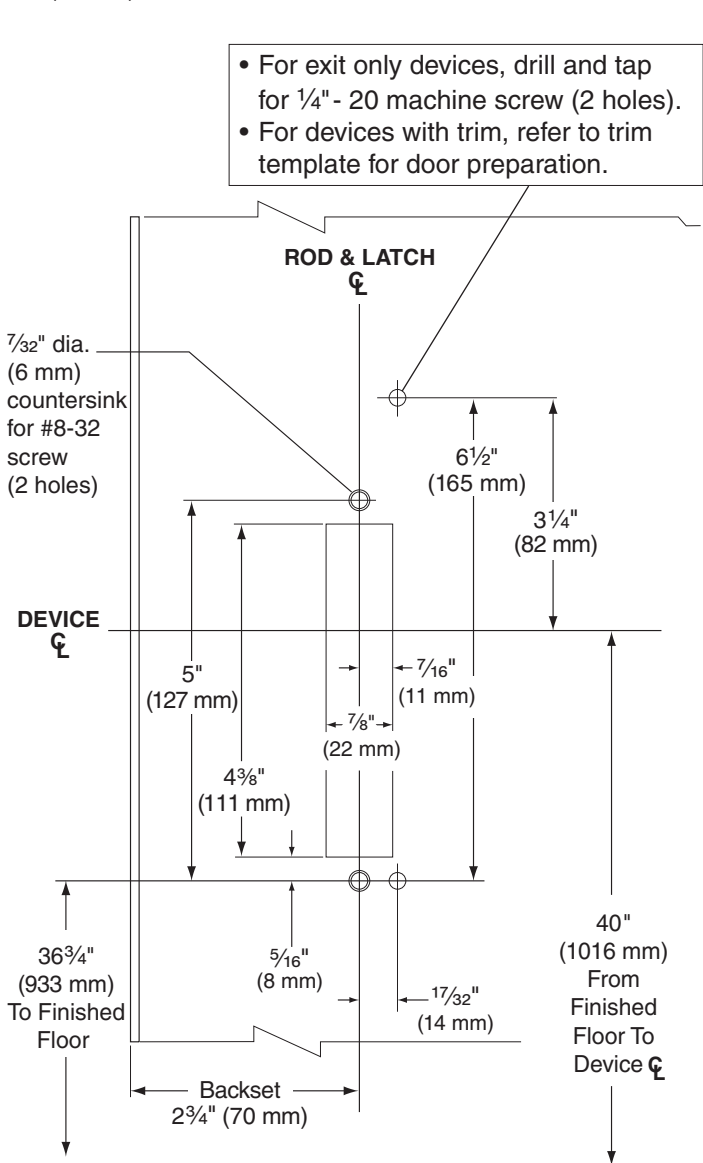

- For outside trim, see trim template for door preparation.
- For Less Bottom Rod (LBR) application, refer to template T-5494 for auxiliary fire latch.
- For sexbolt preparation, refer to Template T-4014.
- See Master Sheet #0100 for suggested reinforcing.

TEMPLATE
T-1140-a